



REFRIGERATION

SERVING THE FOOD INDUSTRY SINCE 1951

## 27-INCH UNDER COUNTER REFRIGERATOR

Item: 27202 Model: RE-CN-0006

*The perfect solution to add cold storage space for frozen products and ingredients conveniently within reach*



### FEATURES

- 430 Stainless Steel exterior
- 304 Stainless Steel interior
- Recessed handles
- Plastic coated steel shelves
- Automatic defrosting
- Ventilated cooling system
- European controller and compressor
- Self-closing doors
- Casters with brakes
- Warranty: 1 year parts and labor and 5 years parts only on compressor



### WARRANTY

1 YEAR PARTS AND LABOR  
5 YEARS PARTS ON COMPRESSOR

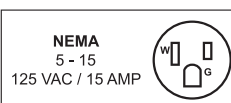

Authorized Dealer

# REFRIGERATION

27-INCH UNDER COUNTER REFRIGERATOR | RE-CN-0006



## PRODUCT SPECIFICATIONS

ITEM NUMBER	27202
MODEL	RE-CN-0006
DESCRIPTION	Refrigerator
TEMPERATURE RANGE	0°C - 10°C / 32°F - 50°F
POWER	0.56 HP / 0.418 kW
REFRIGERANT	R134a
ISOLATION MATERIAL	R141b
COOLING SYSTEM	Ventilated
DEFROSTING	Automatic
TYPE OF CONTROLLER	Mechanical / Digital Display
SELF-CLOSING DOOR	Yes
QUANTITY OF SHELVES	1
HOUSING MATERIAL	SUS304
LINER MATERIAL	SUS304
SHELF MATERIAL	Plastic coated steel
SHELF LOADING (KG/PC)	40 kg. (88 lbs.)
CLIMATE RATING	32°C / 90°F
CONNECTION RATING	4.3 Amps / 385 Watts
ELECTRICAL	115V / 60Hz / 1Ph
INTERIOR DIMENSIONS (WDH)	22.24" x 22.83" x 23.5" 565 x 580 x 596.9 mm
OVERALL DIMENSIONS (WDH)	27" x 29.5" x 35.2" 685.8 x 749.3 x 894.08 mm
PACKAGING DIMENSIONS	29.72" x 32.28" x 38.58" 755 x 820 x 980 mm
NET VOLUME (CU. FT.)	5.5
WEIGHT	170 lbs. / 77 kg.

## TECHNICAL DRAWINGS AND DIMENSIONS

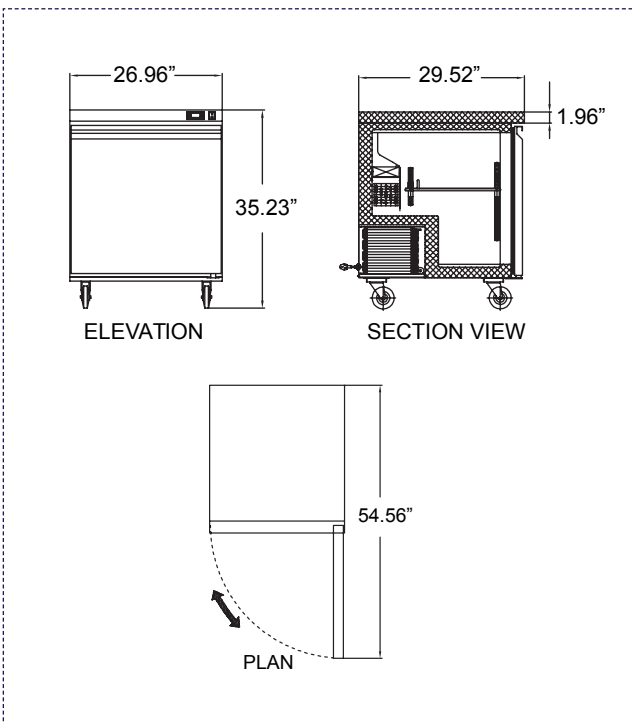

### WARRANTY

1 YEAR PARTS AND LABOR  
5 YEARS PARTS ON COMPRESSOR

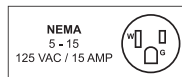

## OMCAN INC.

Telephone: 1-800-465-0234

Fax: (905) 607-0234

Email: sales@omcan.com

Website: www.omcan.com



Follow us to keep up to date with the latest news and offers



2016.E.O.E